

HFA

SHIFT



# SHIFT

The Shift workstation is designed to meet the latest requirements in office usability and function. With its height adjustable top it allows freedom for the user to sit or stand all at the touch of a button.



## DIMENSIONS

Height	Width	Depth
Various	Various	Various

## GENERAL

Origin	Lead Time
Australia	4-5 weeks



## SPECIFICATIONS

Made in Australia

10-year warranty

AFRDI certificate

620 – 1270mm desk height range

Straight C-leg or T-leg, back-to-back, and corner configurations

Weight rating: 120kg on straight desks and 180kg on corners

TIMOTION actuator to each leg

38mm per second travel speed

Anti-collision technology

 Optional Bluetooth connectivity





# HFA



1F Marine Parade  
Abbotsford, Victoria  
3067 Australia

T +61 (3) 9818 8400  
F +61 (3) 9818 6655  
info@hfa.com.au

 ecf.com.au  
 ecf.hfa  
 @ecf\_hfa



# SHIFT

The Sit to stand health benefits may include: lowering your risk of obesity, decreasing your risk of cardiovascular disease, reduce back pain, help improve mood and energy levels, and assist in productivity.



## OPTIONS



Standard Controller: Up/down drive, 3 memory positions, optional Bluetooth connectivity, USB-A charging

Independent Screen

Optional autodrive feature where desk auto drives to a preset height by itself (Using the App)

Segregated Cable Ducting

Dual Screen

Leg to Screen Brackets

Straight C Leg or Straight T Leg

Colours include any Dulux powdercoat for the frame (Internal actuators will be either white or black)





# HFA



1F Marine Parade  
Abbotsford, Victoria  
3067 Australia

T +61 (3) 9818 8400  
F +61 (3) 9818 6655  
info@hfa.com.au

 ecf.com.au  
 ecf.hfa  
 @ecf\_hfa



# SHIFT

The workstation is available in a variety of configurations allowing for straight, 90 and 120 degree angle desks



## CONFIGURATIONS

Configurations include straight, 90 and 120 degree

Seamless adaptability for add ons and re-configuration

Custom sizes available

### SIZES

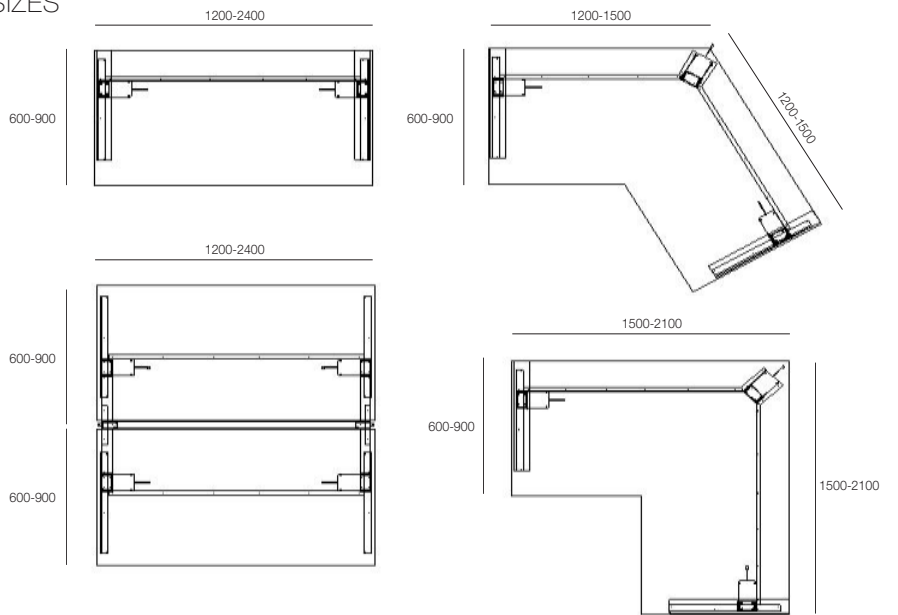

### CONFIGURATIONS

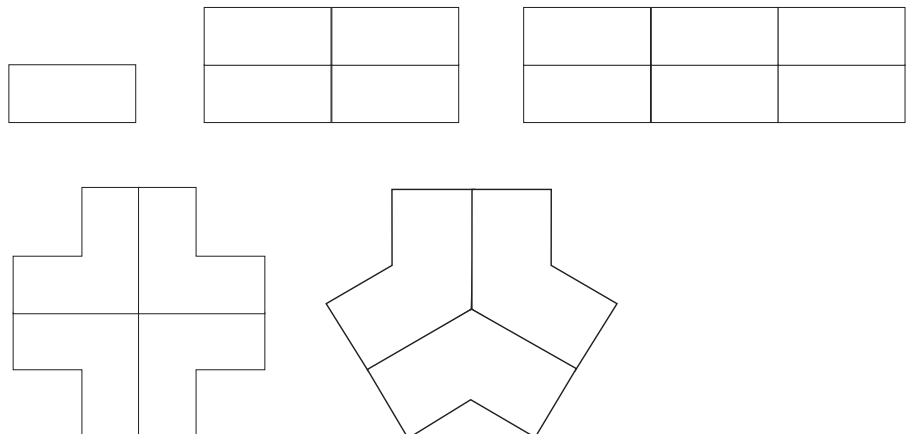

1F Marine Parade  
Abbotsford, Victoria  
3067 Australia

T +61 (3) 9818 8400  
F +61 (3) 9818 6655  
info@hfa.com.au

ecf.com.au  
 ecf.hfa  
 @ecf\_hfa



A range of accessories are available with our range of framed screens including: A4 portrait or landscape tray, wire shelf bracket with metal or melamine shelf, non-perforated metal shelf, coat hook, vertical tray, disc box & pencil tray. Accessory rails can be incorporated into the screen itself for added flexibility.



## ACCESSORIES

Accessories compatible with framed screens include:

- Wire Shelves
- Metal Shelves
- Paper Trays
- Coat Hooks
- Pencil Trays
- Vertical and Spiral Racks

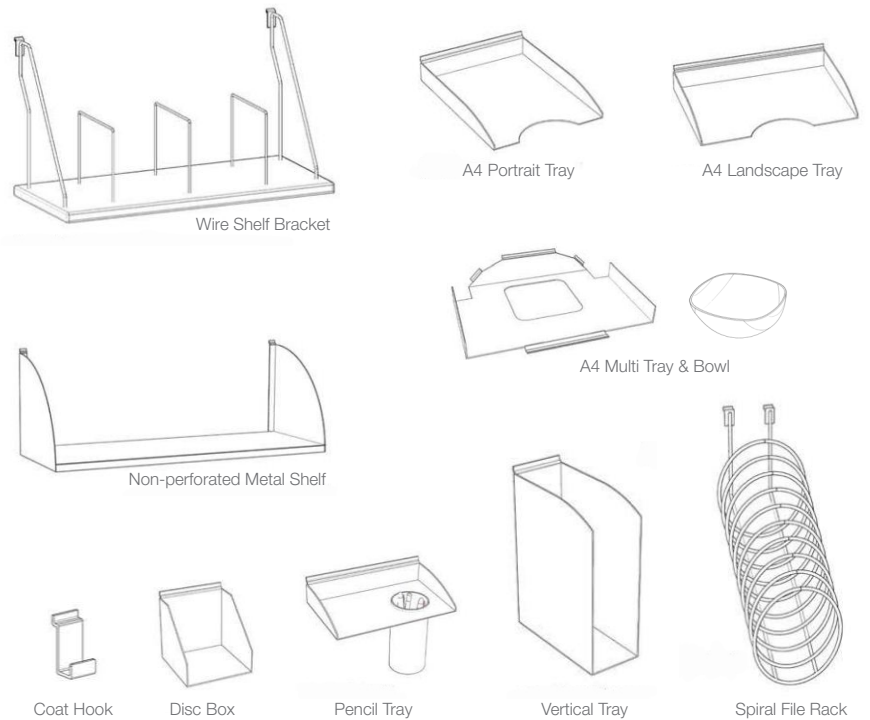

Accessory choice will vary based on screen choice

# SHIFT

A range of screens are available to suit the workstation helping to prevent interruptions and assist in lowering noise levels.

Screen options include: 25, 30 and 55mm Thick ducted or Non Ducted, Acoustic & Fabric Wrapped.

Paired with a 55m Screen gives Trilogy an AFRDI rating



## SCREENS

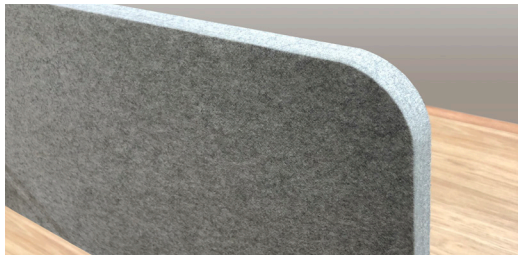

### ACOUSTIC SCREEN

Available in 12 or 24mm thickness in various colours. Typically utilising Autex Cube range which can be put through a water-jet process to enable us to profile various shapes & sizes. Variety of desk mounting options available.

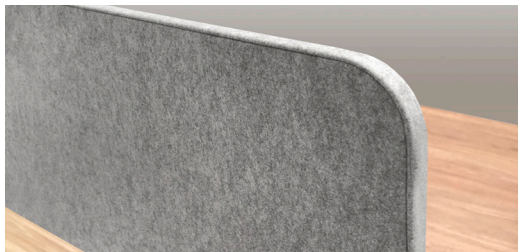

### WRAP SCREEN

30mm thick fully upholstered frameless screen. Profiled to suit various shapes & sizes manufactured using a pinable substrate. Variety of desk mounting options available.



### T50

50mm thick framed screen system. Finishes include upholstered fabric panels, glass, Perspex, Echo Panel / Cube, laminate & timber veneer with powder coated aluminium extruded frame.

Accessories include screen hung shelves, paper - pencil trays, name plates & accessory rail. T55 can also reticulate soft wiring & data through its segregated duct with the ability to mount GPO & Data outlets



### T30

30mm thick framed screen system. Finishes include upholstered fabric panels, glass, Perspex, Echo Panel / Cube, laminate & timber veneer with powder coated aluminium extruded frame.

Accessories include paper - pencil trays, name plates & accessory rail.

HFA



1F Marine Parade  
Abbotsford, Victoria  
3067 Australia

T +61 (3) 9818 8400  
F +61 (3) 9818 6655  
info@hfa.com.au



ecf.com.au



ecf.hfa



@ecf\_hfa

