

# Summit

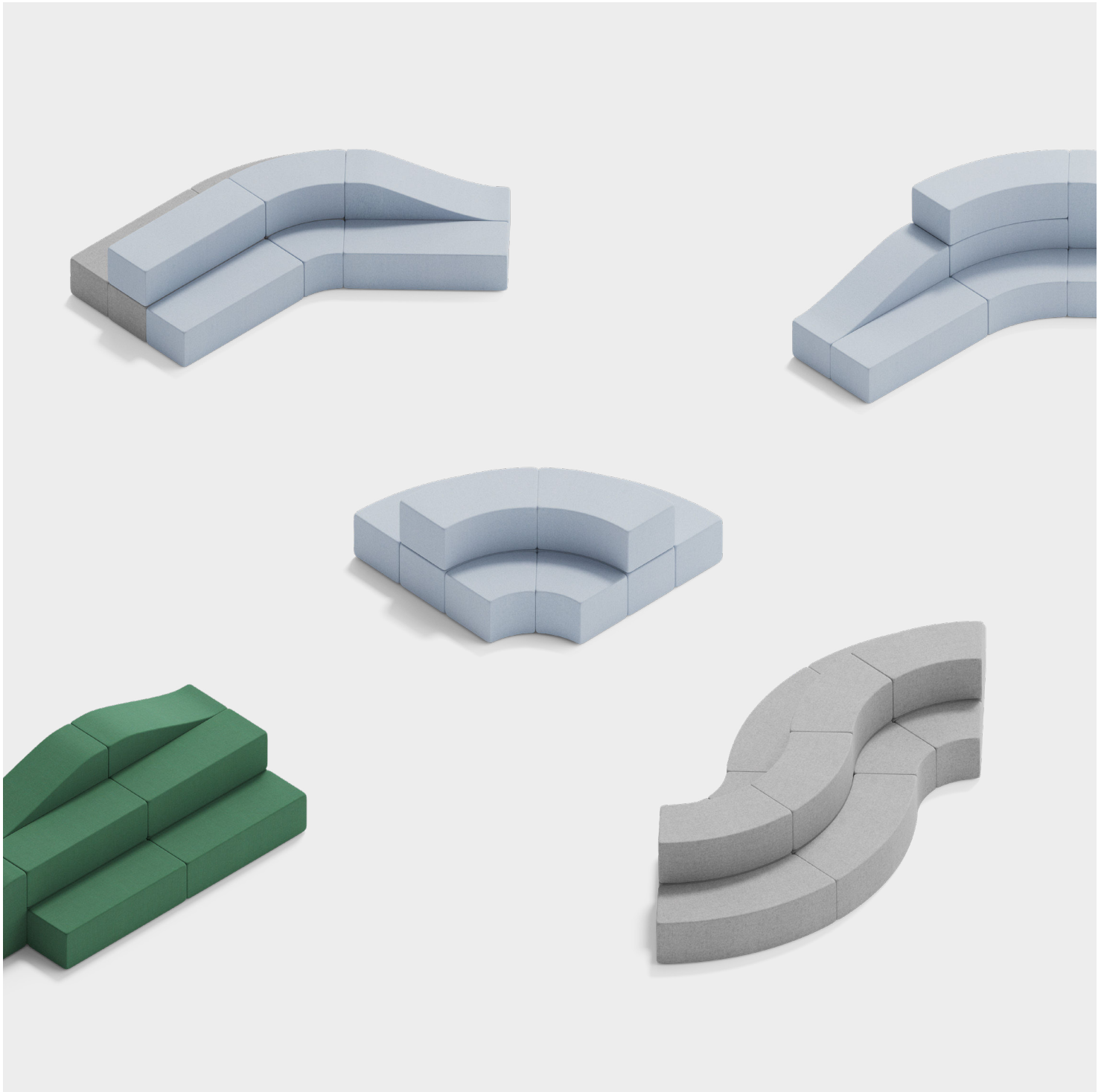

Product sheet — 12102022

**+Halle®**

ecf



1F Marine Parade  
Abbotsford, Victoria  
3067 Australia

T +61 (3) 9818 5444  
F +61 (3) 9818 6655  
info@ecf.com.au



ecf.com.au



ecf.hfa



@ecf\_hfa



Every so often a new piece of furniture is created, adhering to principles of classic space-defining, yet delivering something bold and unconfined.

Norwegian designers at Snøhetta have achieved just that, introducing Summit—a multi-level, modular, seat—as a response to Danish design brand +Halle’s second Annual Briefing on the theme of sharing.

---

## Modules



Curve Small



Curve Medium



Curve Large



Straight



Wave

# Measurements

MODELS:	LENGTH:	DEPTH:	HEIGHT (+2CM WITH FEET):
Curve Small	79 cm	50 cm	38 cm
Curve Medium	119 cm	50 cm	38 cm
Curve Large	158 cm	50 cm	38 cm
Straight	150 cm	50 cm	38 cm
Wave	150 cm	50 cm	38—76 cm

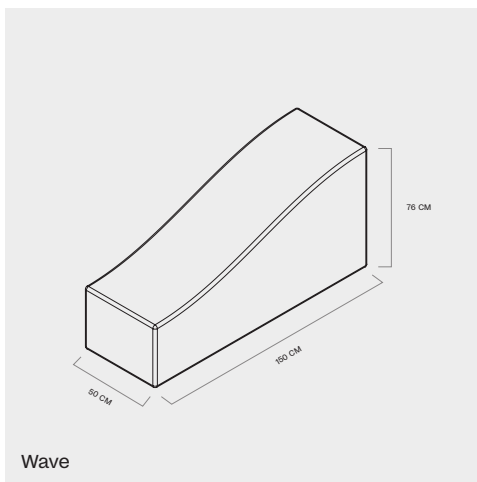
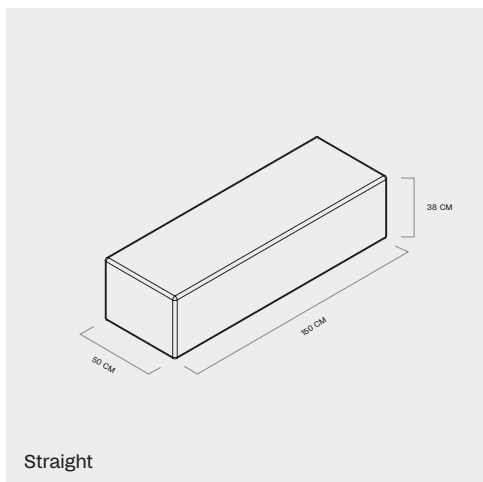
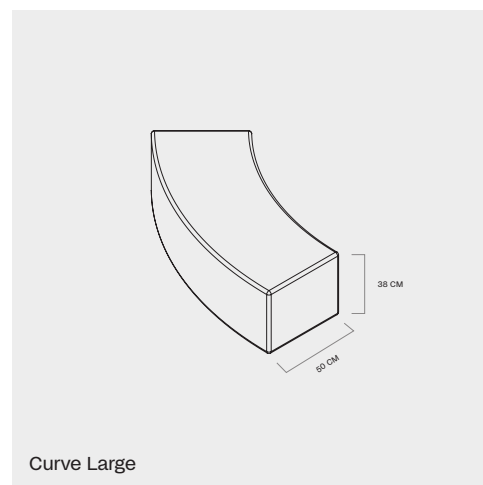
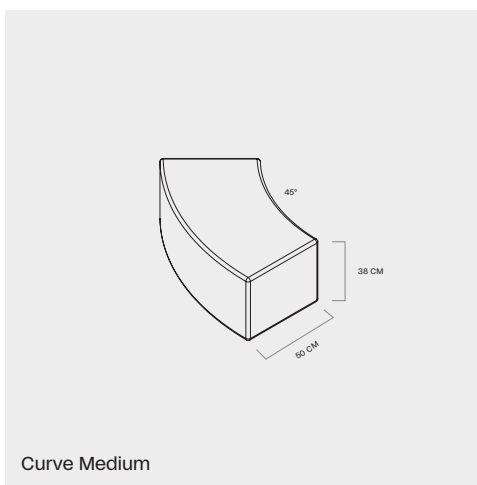
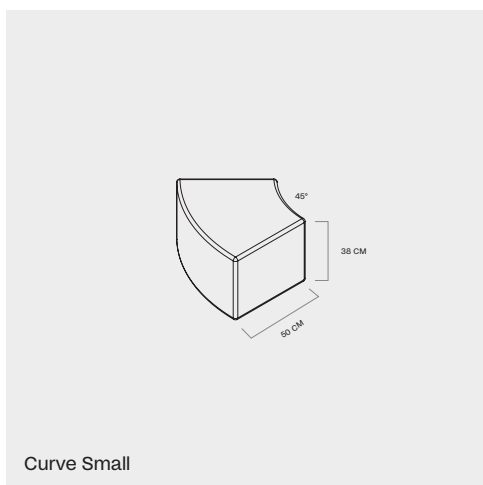

---

# Specifications

---

## Materials

Frame: MDF  
Seat: Foam  
Feet: PA

## Fabrics

Available in all fabrics and leather types

---

## Sustainability

All +Halle products are made according to the highest Danish environmental standards. The wood is grown with respect for the land, and the metal parts are manufactured from 99% recyclable steel. All foam and fabric are developed and tested with compliance to Scandinavian standards. Our factories also take great pride in following the Danish working environment act, reassuring all artisans being happy and safe at all times.

## Tests & certificates

FSC®-163859  
EN15372:2016  
EN16139:2013  
L2 Extreme Use

---

## Designed by Snøhetta

Snøhetta is an international design studio founded in 2005. Since its conception, the studio has burned with a passion for design and its democratic potential. Its belief is that we all have a right to meaningful design.

# Configurations

Please refer to layout name. For other configurations, please include a sketch or description with request.

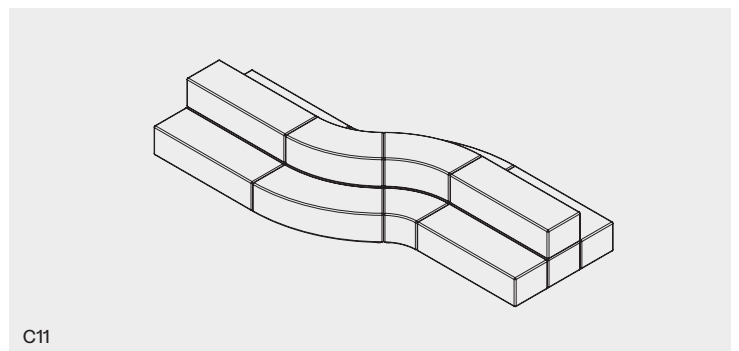
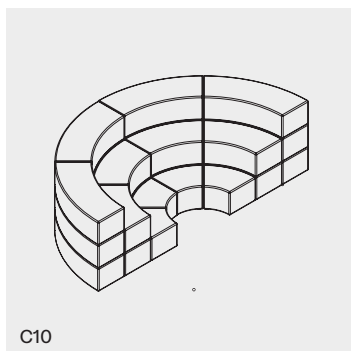
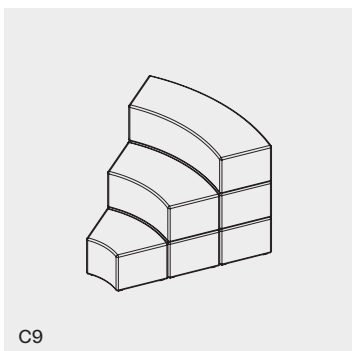
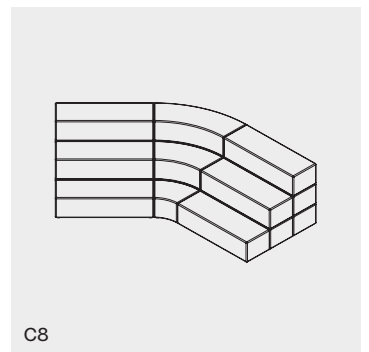
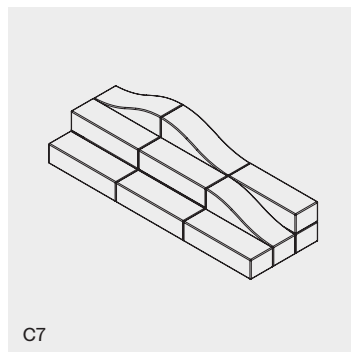
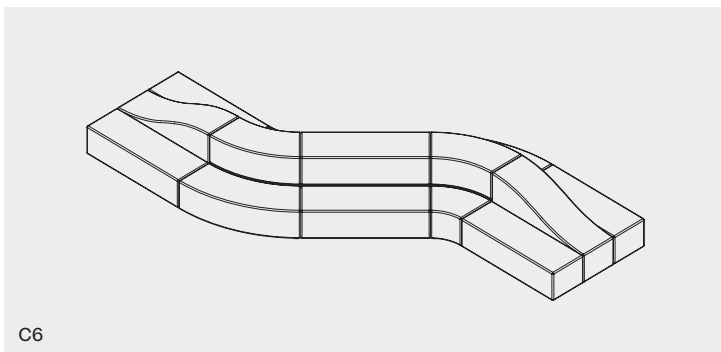
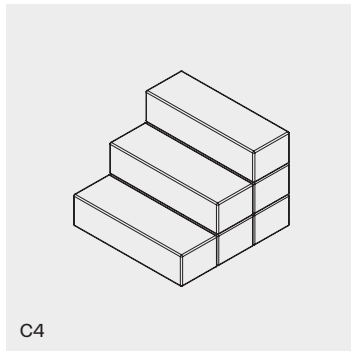
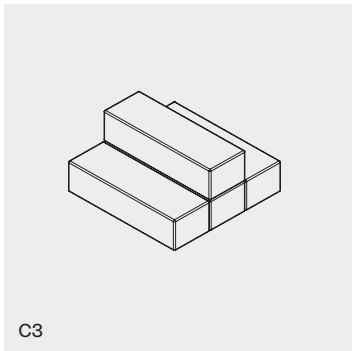
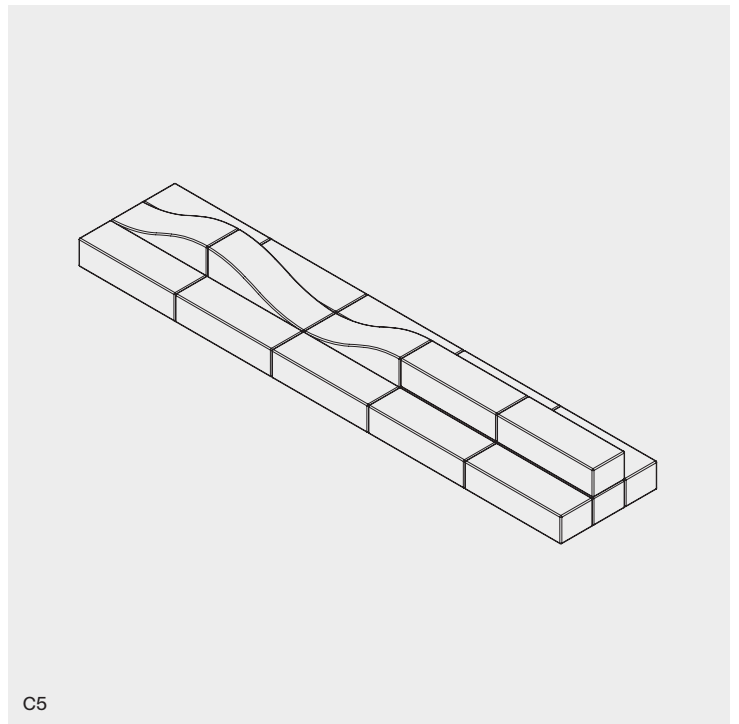
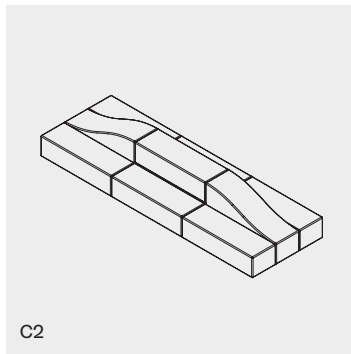
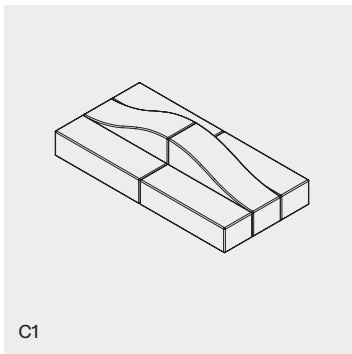

## Featured details



### Optional power plug

Summit offers an integrated power plug solution available for all markets around the world. Summit is versatile enough to allow any entry point, creating an inviting seating set up for the gathering of people. Helped by the many modules, creating a perfect place to share is a comfortable experience, naturally playful and fun.



Available in all fabrics and leather types

# Summit designed by Snøhetta

Every so often a new piece of furniture is created, adhering to principles of classic space-defining, yet delivering something bold and unconfined. Norwegian designers at Snøhetta have achieved just that, introducing Summit—a multi-level, modular, seat—as a response to Danish design brand +Halle's second Annual Briefing on the theme of sharing. 'It's the form in which we gather that makes the brief fascinating: inspired by the idea of furniture acting as a facilitator for exchange, we can see how Summit speaks to new ways of coming together. Traces of landscape architecture feed into the design—introducing a soft, mount-like, structure at play— which remains a reference point for the design to this day,' says Martin Halle, Creative Director at +Halle.

'Summit is an investigation into how a cushioned hillside, with its gentle elevation, can create intimate sharing spaces for people to work, learn and unwind. And while we found the idea of natural escalation thrilling, we saw the opportunity in combining the inherent behaviours of social amphitheatres, open Spanish steps, and playful slopes,' says Marius Myking, Director of Product Design at Snøhetta and he continues. 'We landed on the simple notion of a multitude of levels, an indoor mountain range, providing intimacy without having to create an enclosure.'

Summit is humble, prioritising a warm, soft surface, natural shapes and intuitive playfulness without embellishment. During the Annual Briefing, a behavioural-led design forum held in Copenhagen, Stockholm, and Oslo during 2019, Snøhetta curiously explored the concept of an architectural tool, for open, and less-prescribed sharing. The main purpose: providing a set of shapes that can serve the right dynamic based on the need of each situation, whether it be a lecture, a meeting or a momentary break. 'For us, it's important, that people can make it their own,' says Myking.

A mountainous landscape, Summit draws you in, with complete upholstery, beautiful stitching, and soft cushioning, it is a retreat from conventional furnishings. With six modules: curved, waved and straight, in three sizes: small, medium, and large, the modulations are endless. 'When prototyping and testing Summit with our architect colleagues, the forms worked intuitively. We deliberately avoided any rules, emphasising creativity and the immediate play that occurred, proved a good dose of natural immersion.'

Simple in its form, Summit can become a small staircase, a curved rising or a wavy ridge, all depending on the preferred environment. Myking says that one of the strengths is the ability to continuously redefine a room using the same footprint: 'We have two Summits in the Snøhetta office in Oslo, each consisting of five modules. Throughout the day the modules might be turned and suddenly you have a different setting using the same floor space' he explains.

Martin Halle is fascinated by the many clever features the architects have come up with so far: he shows a couple of different configurations and smiles: 'It's totally up to interpretation, whichever accommodation you need. Sometimes that is a small island or a large installation, but it's when the hills come together that it defines the context,' he says.

Summit is versatile enough to allow any entry point, creating an inviting seating set up for the gathering of people. Helped by the many modules, creating a perfect place to share is a comfortable experience, naturally playful and fun. 'The system defines spaces without enclosing them: rather than having a private, secretive meet-up, Summit brings generosity and freedom of use, somewhat unexpectedly. It is good to be serious, but at times it is equally important to add a little bit of fun,' Myking reflects. 'You must interact with Summit, by lying, or leaning, exploring different ways of using it, sitting differently from one day to another. The purpose is to facilitate that diversity in use, highlighting the value of creating environments for individual needs coming together,' Halle concludes.

—→ Learn more about the this product and download assets  
<https://plushalle.com/products/summit/>



**+Halle®**

ecf



1F Marine Parade  
Abbotsford, Victoria  
3067 Australia

T +61 (3) 9818 5444  
F +61 (3) 9818 6655  
info@ecf.com.au



ecf.com.au



ecf.hfa



@ecf\_hfa

