

HFA

QUEENSCLIFF



QUEENSCLIFF

The Queenscliff has a regal appeal with its detailed curved back and optional studding feature to emphasize its stunning design. This winged back armchair can be used within a formal entrance way or looks very opulent and luxurious set around a fireplace environment as an aged care armchair.



DIMENSIONS

Height	Width	Depth
1050mm	850mm	900mm

SPECIFICATIONS

- Made in Australia
- 5 year warranty
- Fire retardant seat foam
- Solid timber legs in clear lacquer
- Upholstered in any suitable fabric, leather or vinyl

OPTIONS

- Curved inside of backrest
- Studs running along the seams
- Colour stain matching

GENERAL

Origin	Lead Time
Australia	4 weeks

TECHNICAL DRAWINGS

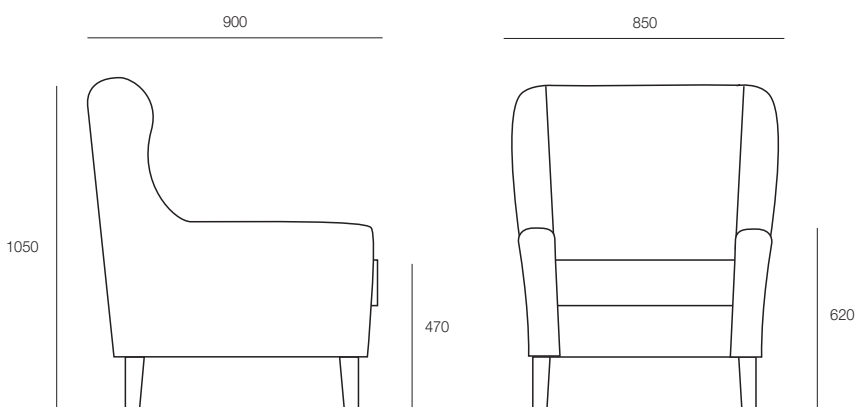

PRODUCT OPTIONS

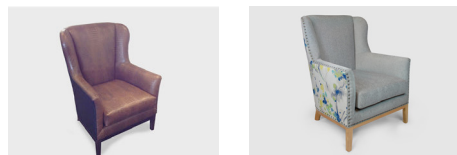



HFA



1F Marine Parade
Abbotsford, Victoria
3067 Australia

T +61 (3) 9818 8400
F +61 (3) 9818 6655
info@hfa.com.au

 ecf.com.au
 ecf.hfa
 @ecf_hfa

