

HFA

AERIAL WORKSTATION



Neat. Tidy. Sleek.

The latest Vidak workstation offers a refined, contemporary aesthetic without compromising on quality.

Concealed cable management for a tidy office.

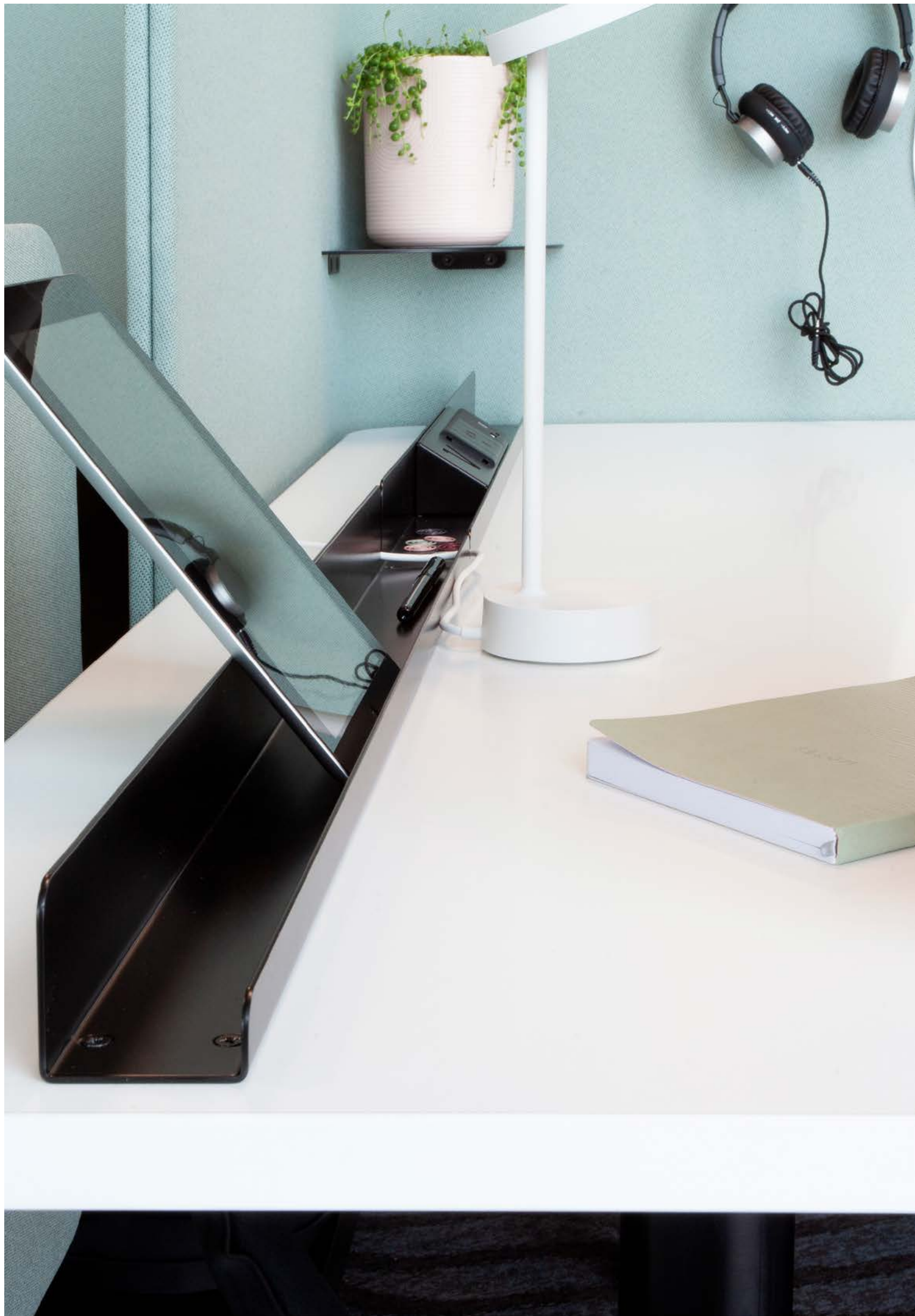

# Worksystems

---

## Aerial

---

Aerial is Vldak's latest electric height-adjustable worksystem. With its slim, round leg Aerial offers a lighter, contemporary aesthetic without compromising on quality or sturdiness. Users can transition effortlessly from sitting to standing at the press of the button - promoting healthier work habits.

Specifically designed to meet the recently updated Aus/NZ quality standards for workstations, Aerial's generous leg space and height range provides a more comfortable working experience. The quiet twin-motors easily lift the weight of an average worktop with computer equipment (and maybe the occasional lazy elbow!).

Concealed cable management will appeal to those who like a tidy office and workstations can be reconfigured from single to back-to-back configurations to satisfy future-minded business owners. Multiple accessories allow for personalisation including screens, shelves, document holders and pen rails.





# Worksystems

---

## Aerial

---

### FEATURES

Fixed height or Electric sit-to-stand desk.

Height

Fixed height: 720H

Electric Sit-to-stand: 620H min - 1270H max

Worktop Dimensions:

1200-2100L x 700-800W

Custom shapes and sizes available.

Slim round leg column design.

Frame speed when in motion: up to 35 mm/s.

Concealed cable management

Load capacity: 80kg (800N) per leg

Powdercoated frame in black or white.

Castors available on freestanding desks and 2pods .

Desk-mounted or frame-mounted screen options.

Simple kit of parts offers future flexibility.

Workstations can be reconfigured from freestanding desks to 2pod configurations since they use the same frames and many of the same components.

Handset controller with position memory function.

Integrated collision avoidance system prevents material damage or injury. System automatically reverses direction if desk makes contact with a solid object in motion.

GreenTag (pending)

AS/NZS 4442:2018

ISO14001



---

**Aerial - fixed height - freestanding**



---

**Aerial - sit to stand - 2pod (shared frame)**



---

**Aerial - sit to stand - 3pod 120degree**

# Worksystems

## Aerial

### Height adjustment control

#### FEATURES

Handset controller has position memory function. Heights can be preset for ease of use and has an LCD display that displays the current height position.

Integrated collision avoidance system prevents material damage or injury. System automatically reverses direction if desk makes contact with a solid object in motion.

Can be used with Vidak ViDesk app. This puts the user in direct communication with their Vidak sit-to-stand workstations and enables height adjustments directly from your mobile device. Requires a Bluetooth Dongle, QR code and Control Box.

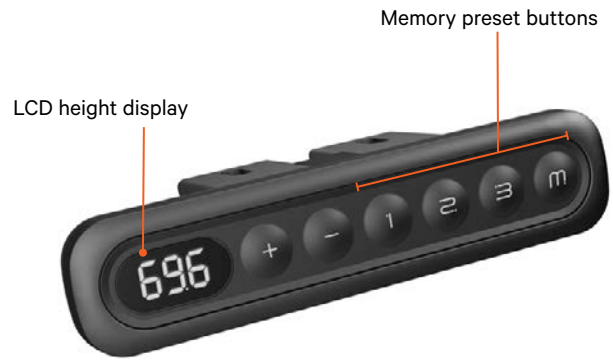

#### Aerial handset controller



#### Use with the Videsk app to control via mobile device



#### Bluetooth dongle, QR code + control box





# Worksystems

## Aerial

Height adjustment range

### FEATURES

Height range: 620mm (min) - 1270mm (max)

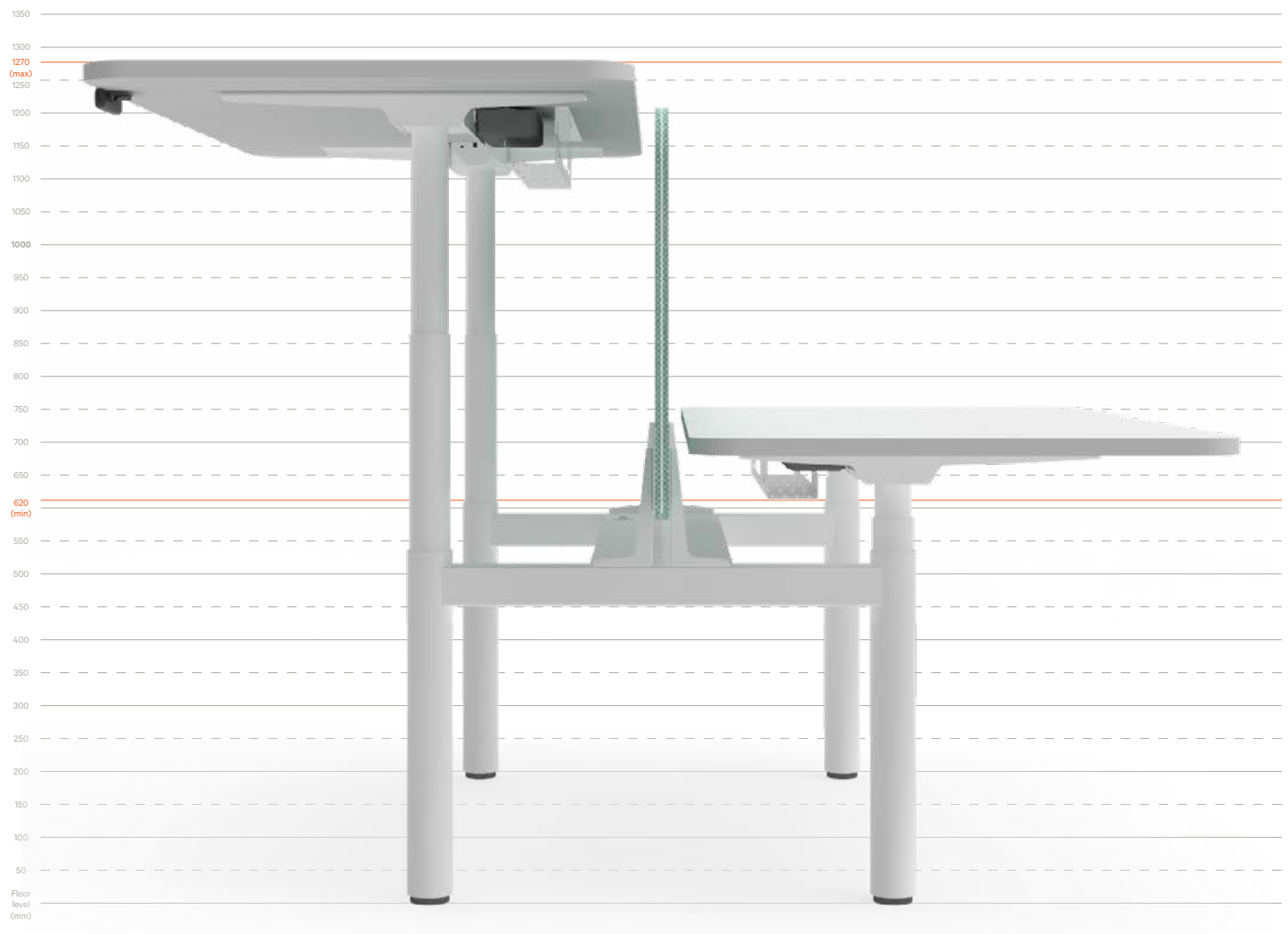

Aerial height adjustment profile

# Worksystems

## Aerial

### Configurations

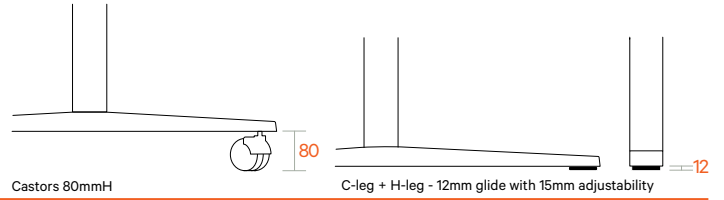

Castor and Glide details

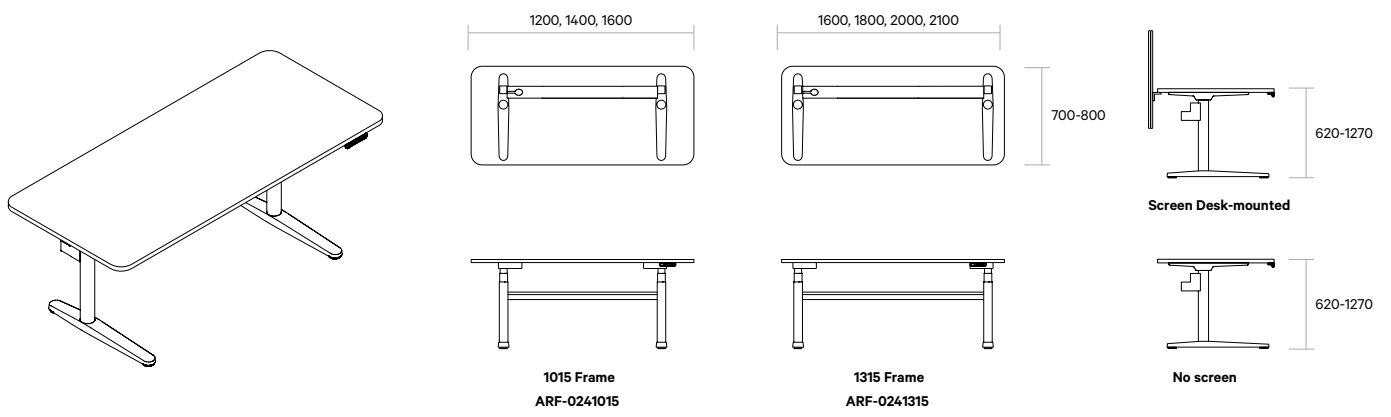

### Freestanding - No Screen or Screen Desktop-mounted

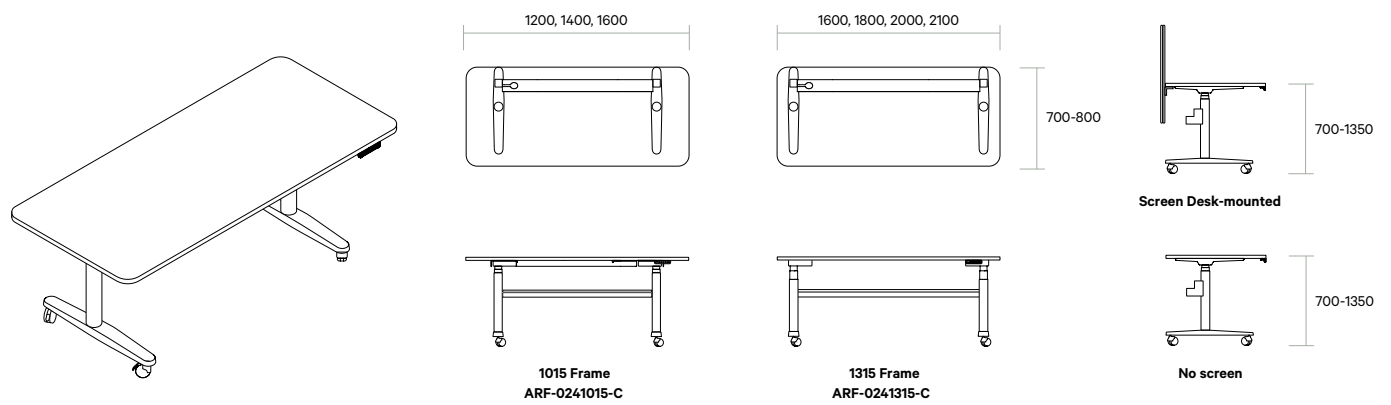

### Freestanding on castors - No Screen or Screen Desktop-mounted

# Worksystems

## Aerial

### Configurations

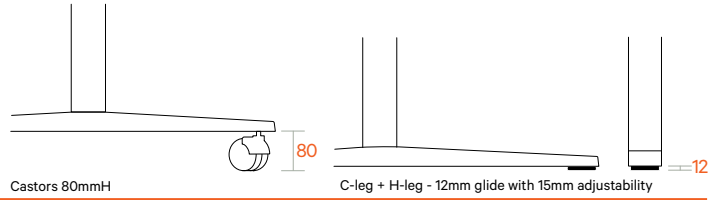

Castor and Glide details

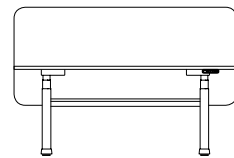
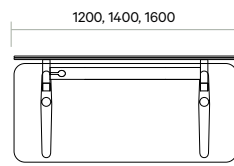
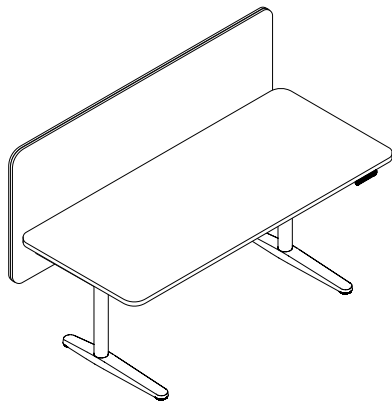

1015 Frame  
ARF-0241015

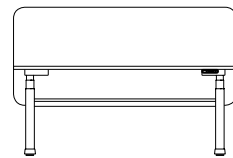
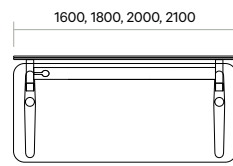

1315 Frame  
ARF-0241315

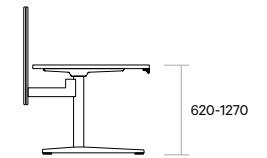
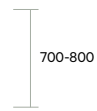

Screen Frame-mounted

### Freestanding - with Screen Frame-mounted

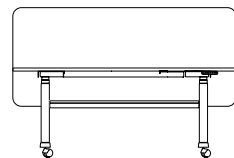
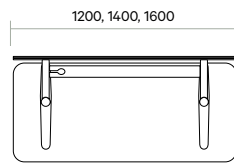
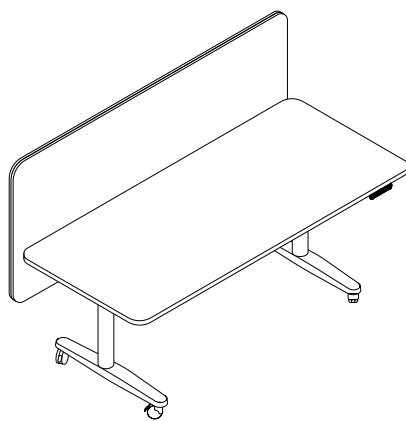

1015 Frame  
ARF-0241015-C

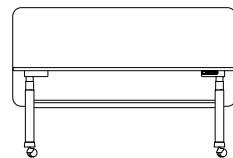
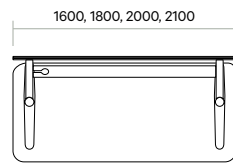

1315 Frame  
ARF-0241315-C

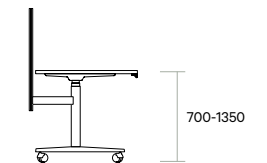

Screen Frame-mounted

### Freestanding on castors - with Screen Frame-mounted



# Worksystems

## Aerial

### Configurations

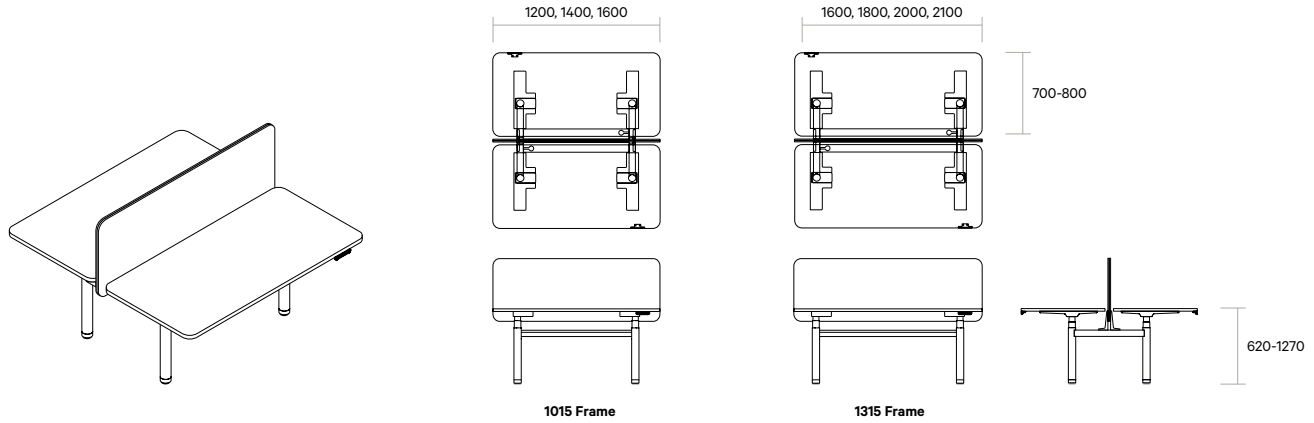

### Straight 2pod - With Beam Mounted Screens

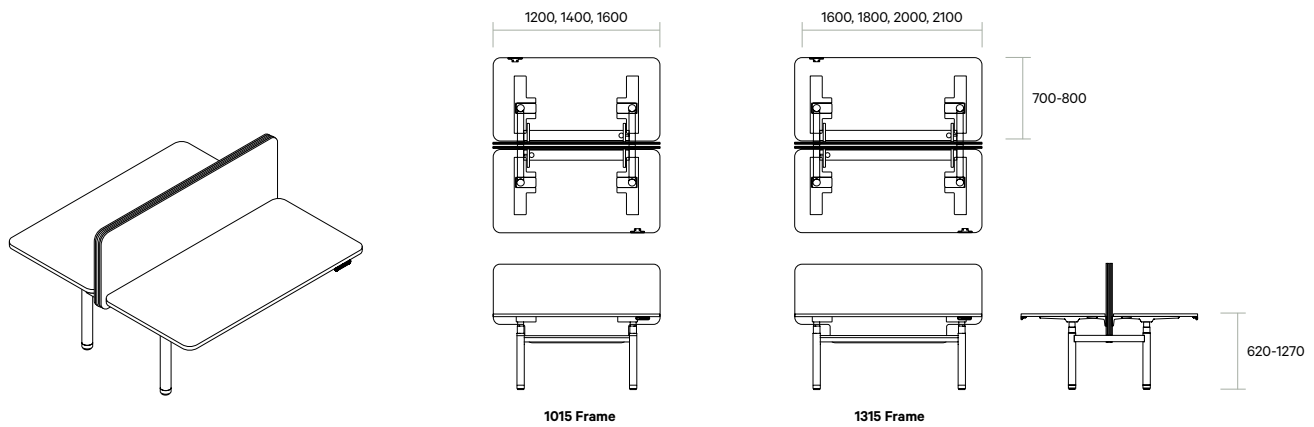

### Straight 2pod - With Desk Mounted Modesty Screens

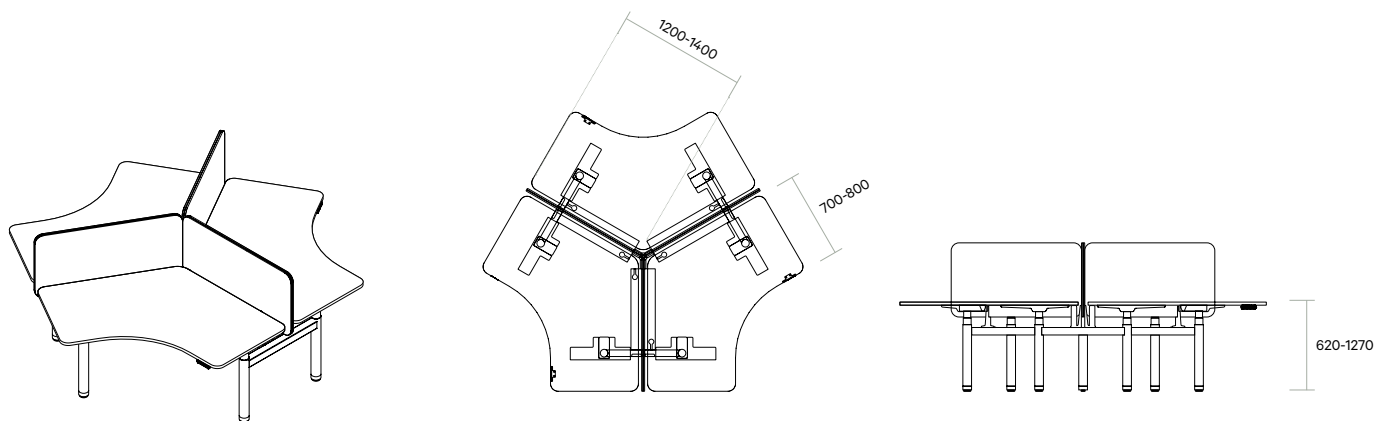

### 120deg 3pod with beam mounted screens (1500W + freestanding desks also available)

# Worksystems

## Aerial

### Worktop Options

#### FEATURES

Standard Width's:

1200,1400,1600,1800,2000 and 2100mm

Standard Depth's: 700, 750 and 800mm

Custom size and shape to suit your requirements.

25mm thick low emission MDF board

Finishes: Low- or high-pressure laminate, veneer finish or solid timber

Matching ABS or tekton edging

Optional cable port hole or cutout Scallop for cable management

Optional 70mm radiussed corners

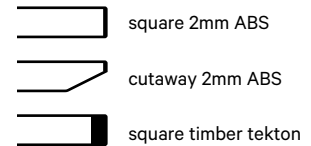

#### Edge detail options



#### Square Corners

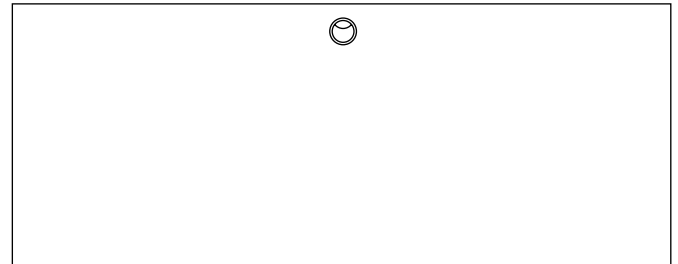

#### Cable port hole



#### 70mm radiussed corners

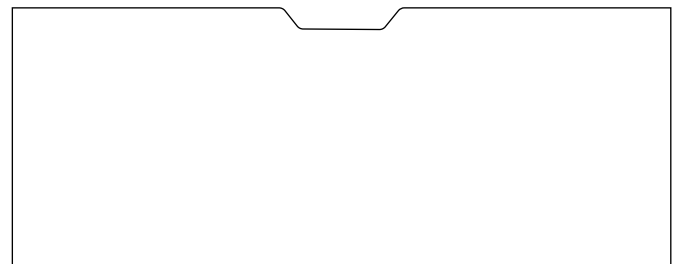

#### Cable cutout - Scallop

# Worksystems

---

## Aerial

---

### Divide Screens

---

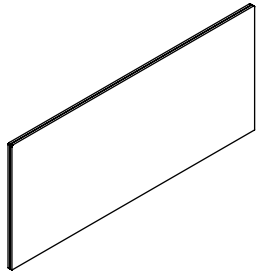

---

**Straight Corners**

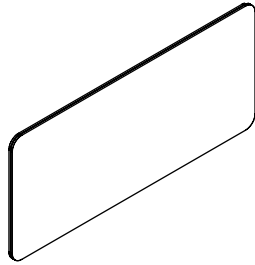

---

**Radiussed Corners**

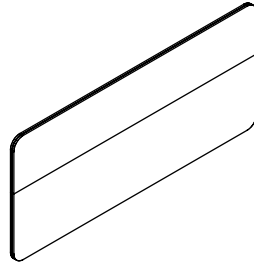

---

**Split Fabric**

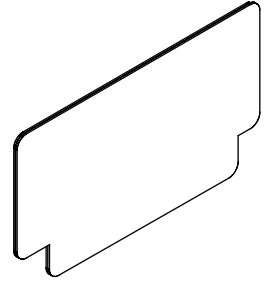

---

**Modesty Panel**

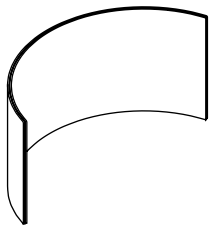

---

**Rounded Screen**

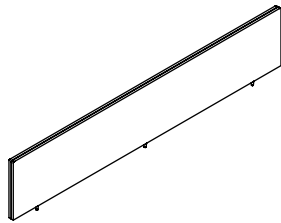

---

**Stacking**

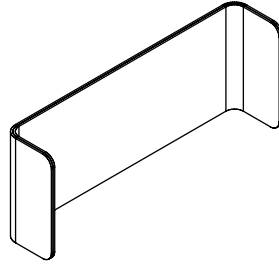

---

**Wrap-Around (Full)**

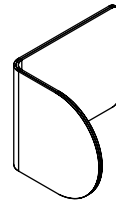

---

**Wrap-Around (Half)**

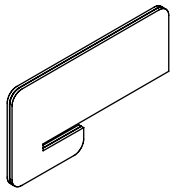

---

**Slide-On Rectangular**

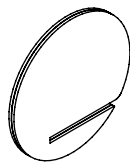

---

**Slide-On Circular**

Also compatible with:



---

**Edge**



---

**Screenliner**

# Worksystems

---

## Aerial

---

### Freestanding screen mounting options

---

#### FEATURES

Screens can be mounted to the frame or to the desktop.

Screens Frame-mounted remain static regardless desk height adjustment.

Screens Desktop-mounted move up and down with the desk.

---



---

**Aerial freestanding - No screen**



---

**Aerial freestanding - with Screen Frame-mounted**



---

**Aerial freestanding - with Screen Desktop-mounted**



# Worksystems

---

## Aerial

---

### 2pod screen mounting options

---

#### FEATURES

Screens can be mounted to the frame or to the desktop.

Screens Frame-mounted remain static regardless desk height adjustment.

Screens Desktop-mounted move up and down with the desk.

For a desktop-mounted Divide screen with modesty panel, a twin cable tray is required to allow enough space for the modesty screens to lower in between the desks.

---



---

**Aerial 2pod - Frame-mounted Screen**



---

**Aerial 2pod - Desktop-mounted screen (Dual cable tray)**



---

**Aerial 2pod - Desktop-mounted screen (twin cable tray)**

# Worksystems

---

## Aerial

---

### Integrated cable trays

---

#### FEATURES

Standard cable tray options include Single tray (for freestanding desk), Dual tray (for 2 pod) or Twin tray (for 2 pod with modesty screen)

Powdercoated steel construction

Integrated cutouts for power and data outlets

Separation for power and data cabling and slots along the length to allow for Velcro or cable ties to keep the cables in place.

Cable tray lids keep all cables hidden within the trays for a seamless look

---



**Single tray on freestanding desk**



**Dual tray on 2pod**



**Twin cable tray on 2pod**

# Worksystems

---

## Aerial

---

### Cable Management Options

---

#### FEATURES

Underdesk tray keeps monitor and power cords secured and static below desktop. This means less risk of damage to the cords because they don't move when the desktop is adjusted. This offers a tidier solution with most cables secured under the desktop.

Underdesk cable sling is alternative to the underdesk tray which provides streamlined cable management for cables underneath the desktop. Power outlets are also mounted to the underside of the desktop.

Cable sleeves are stretchy neoprene velcro and link power and data cords between cable tray and desktop.

---

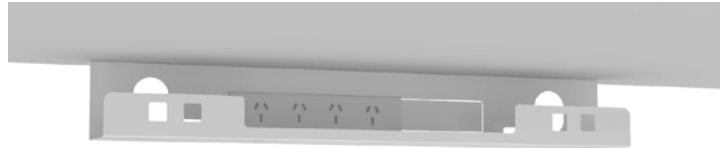

**Underdesk tray**



**Underdesk Cable Sling**

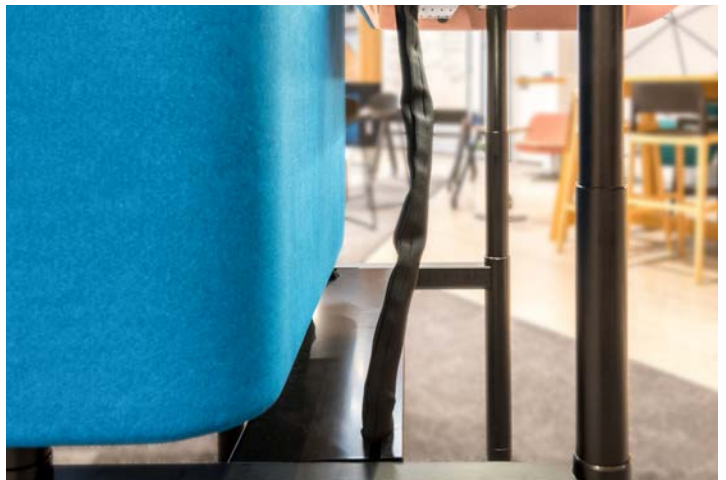

**Cable Sleeve**

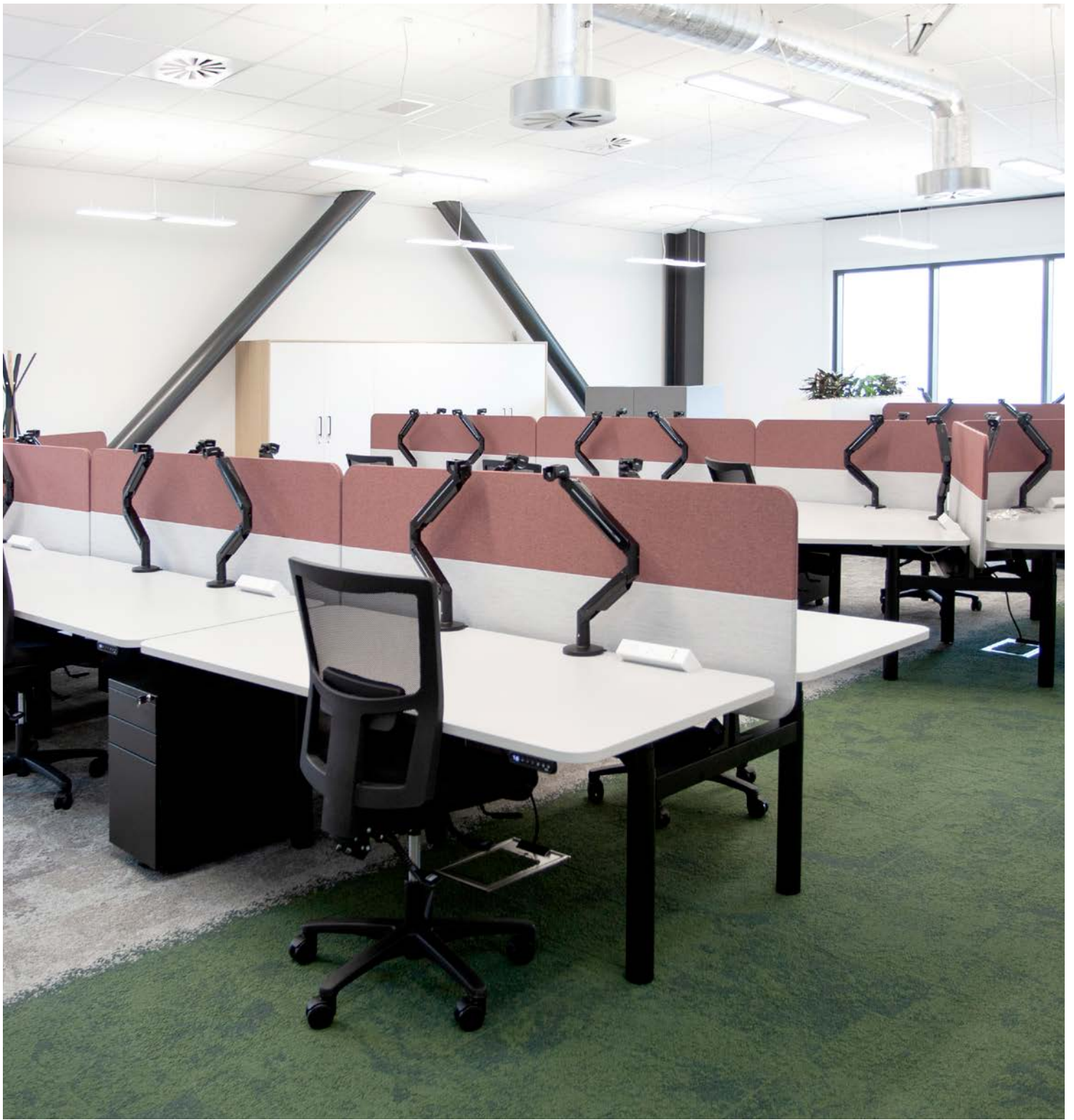



**HFA**



1F Marine Parade  
Abbotsford, Victoria  
3067 Australia

T +61 (3) 9818 8400  
F +61 (3) 9818 6655  
info@hfa.com.au

 [ecf.com.au](http://ecf.com.au)  
 [ecf.hfa](https://www.facebook.com/ecf.hfa)  
 [@ecf\\_hfa](https://www.instagram.com/ecf_hfa)

