

Inspiring
spaces

Martela

PODWORK

DESIGN o4i Design Studio



Product code number:

Screens (height 130 cm):

2983A1/A2 = 130 x 85 cm
2983B1/B2 = 130 x 155 cm
2983CR/CL = 124 x 115 cm
2983D = 130 x 67 cm

Table tops:

2983TLA/TRA = 145 x 100/85 cm
2983TLB/TRB = 145 x 80/70 cm
2983TC = 145 x 60 cm
E = electronic height adjustment

Adjustments:

Table tops 2983TLB/TRB and 2983TC:

electrical height adjustment 65-130 cm.

Screens: height adjustable glides.

Accessories: Table top with electrical height adjustment.

Material description:

Screen fully upholstered.
Table top white laminate.



ecf



1F Marine Parade
Abbotsford, Victoria
3067 Australia

T +61 (3) 9818 5444
F +61 (3) 9818 6655
info@ecf.com.au



ecf.com.au



ecf.hfa



@ecf_hfa



Quality
ISO 9001



Environment
ISO 14001



PODWORK

DESIGN o4i Design Studio

Inspiring spaces

Martela

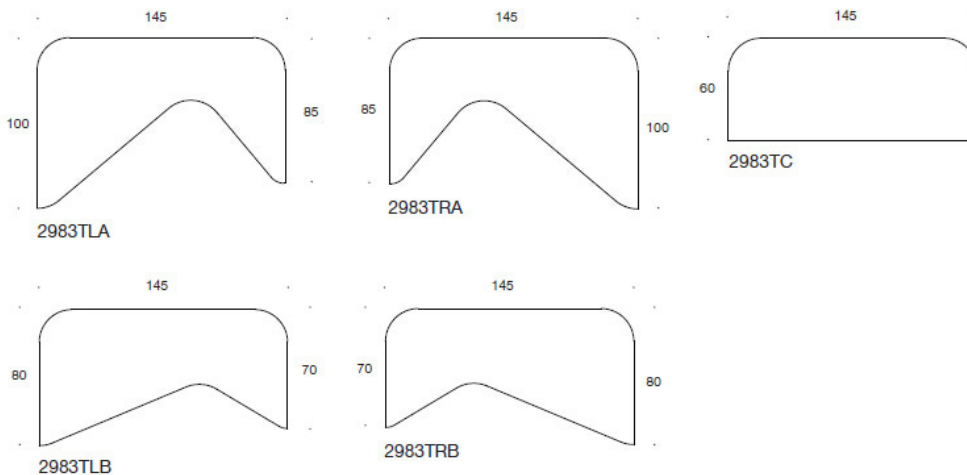
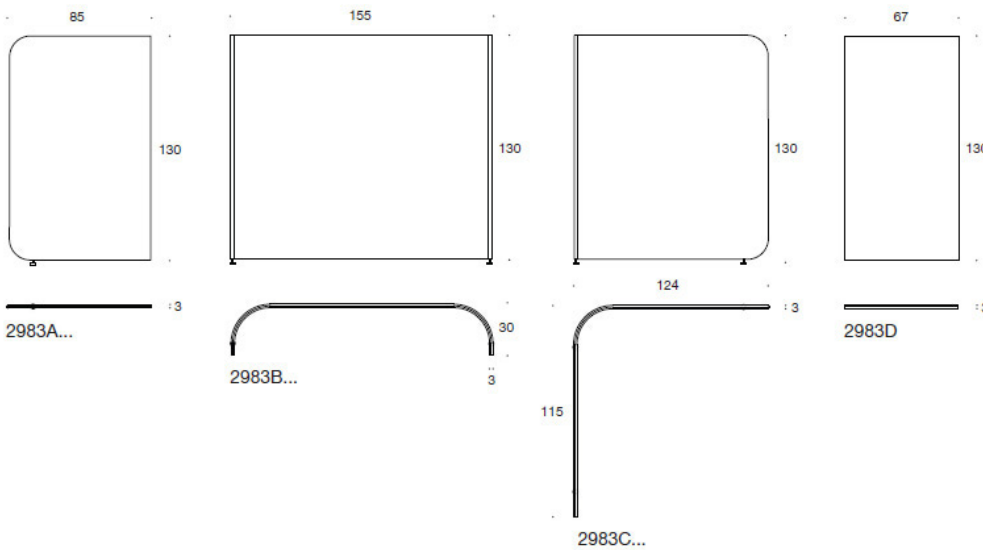
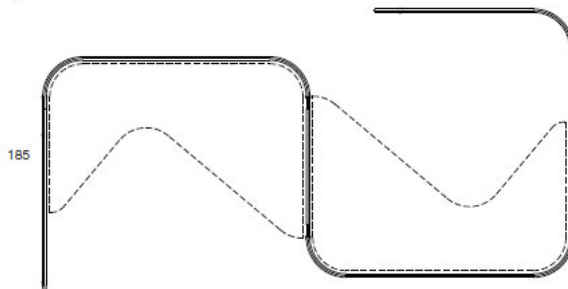
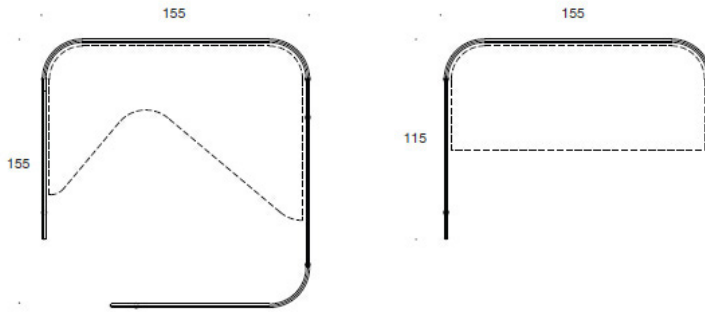



ecf



1F Marine Parade
Abbotsford, Victoria
3067 Australia

T +61 (3) 9818 5444
F +61 (3) 9818 6655
info@ecf.com.au

 ecf.com.au
 ecf.hfa
 @ecf_hfa

