

HFA | NET



# NET

The Net Visitor chair is a light, practical chair suitable for many uses including meeting rooms, lunchrooms, training rooms and waiting areas. The chair comes with a perforated polypropylene back and an optional upholstered seat. It is also available in a high stool version. This chair has stacking capabilities and comes in a variety of colours.



## DIMENSIONS

Height	Width	Depth
840mm	590mm	460mm

## SPECIFICATIONS

- 5 year warranty
- Polypropylene seat and back
- Polished chrome sled frame
- Stackable

## OPTIONS

- Upholstered seat pad
- Fixed arm rests
- Arms

## GENERAL

Origin	Lead Time
Europe	3 weeks



## TECHNICAL DRAWINGS

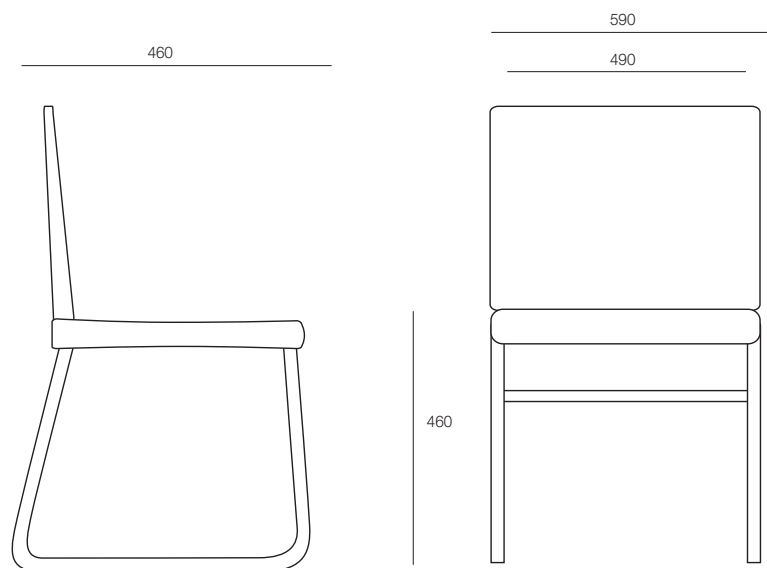

## PRODUCT OPTIONS



HFA



1F Marine Parade  
Abbotsford, Victoria  
3067 Australia

T +61 (3) 9818 8400  
F +61 (3) 9818 6655  
info@hfa.com.au

ecf.com.au  
 ecf.hfa  
 @ecf\_hfa

